

Optris Xi-Profinet interface

1	GENERAL.....	2
2	DESCRIPTION	2
3	PROFINET COMMUNICATION SETUP FOR THE IMAGER.....	2
3.1	CONNECT THE PROFINET INTERFACE BOX.....	3
3.2	PREPARING THE IMAGER FOR PROFINET COMMUNICATION	4
4	MANAGE THE COMMUNICATION.....	8
4.1	INSTALLING GSD FILE	8
4.2	INSTALLING PLC	9
4.3	CONFIGURE THE PROFINET INTERFACE	10
4.4	ADD OPTRIS XI-PROFINET INTERFACE.....	11
4.5	RENAME OPTRIS DEVICE.....	12
5	COMPILING THE PROJECT	14
6	STRATING THE PROJECT.....	15
6.1	SHOW THE DEVICE DATA.....	15
7	READ AND WRITE DEVICE INFORMATION	18
8	READ AND WRITE DEVICE SETTINGS.....	19
9	TUNNEL COMMANDS – DIRECT DEVICE COMMUNICATION.....	20
10	CONTACT INFORMATION.....	21

1 General

The Optris Xi-Profinet interface allows the use of our Xi ETH series imager with the Profinet communication protocol. The Xi-Profinet interface has a M12 D-coded 4 pin female connector for communication to PLC, installed in the electronic box. For the connection with the imager, you need in addition the interface cable **[ACXIIOCBx]**, which is in the scope of supply with your imager. Other lengths and high temperature option is also available.

It is suited for industrial Ethernet with an IP67 protection rate. An extra implemented software stack guarantees the Profinet communication functionality.

2 Description

Optris Xi-Profinet interface basic characteristics:

- Device class: adapter device
- Device type: 06h
- Connection: 1 x M12
- Transfer speed up to 100Mbit/s full-duplex, auto-negotiation capable

The Optris Xi-Profinet interface maps the object temperature, internal temperature, device status, and other imager data to its input assembly which is then sent onto the Profinet network using CIP. In the initialization phase, the Optris Xi-Profinet interface sends the device's configuration data which is accessible for setup via the PLC programming software Controller Tags. Furthermore, Optris Xi-Profinet interface allows you to change a subset of parameters in data exchange mode using different classes.

3 Profinet Communication Setup for the imager

To establish Profinet communication between the imager and your PLC, the following steps must be completed:

- Connect the Profinet Interface Box

The Profinet interface box must be physically connected to the imager. For step-by-step guidance on this process, refer to Chapter **3.1 Connect the Profinet Interface Box**.

- Prepare the imager

Before initiating the Profinet communication, ensure that the imager is properly configured. Your imager sends the temperature data of several measuring areas via the digital Process Interface. For this purpose, you have to define the measuring areas, refer to Chapter **3.2 Preparing the imager for Profinet Communication** for detailed instructions.

- Manage the Communication

Once the hardware setup is complete, the Profinet communication parameters must be configured and managed. Detailed instructions for this process can be found in Chapter **4 Manage the Communication**.

By following these steps, you will ensure a seamless integration of the imager into your Profinet network, enabling efficient data exchange with your PLC.

3.1 Connect the Profinet Interface Box

Remove the terminal block from the supplied PIF cable. Open the cover of the Profinet Interface Box and feed the cable through the cable gland on the side. Unscrew the cable gland and guide the washers and rubber seal over the cable. The cables of the PIF cable have different colors. Connect the wire end ferrules of the PIF cable corresponding the colors on the Profinet Interface Box, like shown in the picture below.

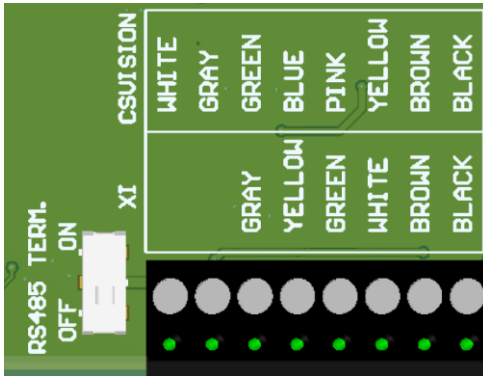

Picture 1: Connectors on the Profinet interface Box

Now connect the Profinet Interface Box to the 12-24 VDC power supply, the imager will be powered by the Profinet Interface Box.

The imager has two connector plugs (see: **Picture 2**) integrated in the sensor backplane. Connect the other end of the PIF cable to the PIF-connector on the right side.



Picture 2: Backplane of the imager

Now connect the Profinet Interface Box with the Ethernet cable to your PLC or network and start the imager configuration.

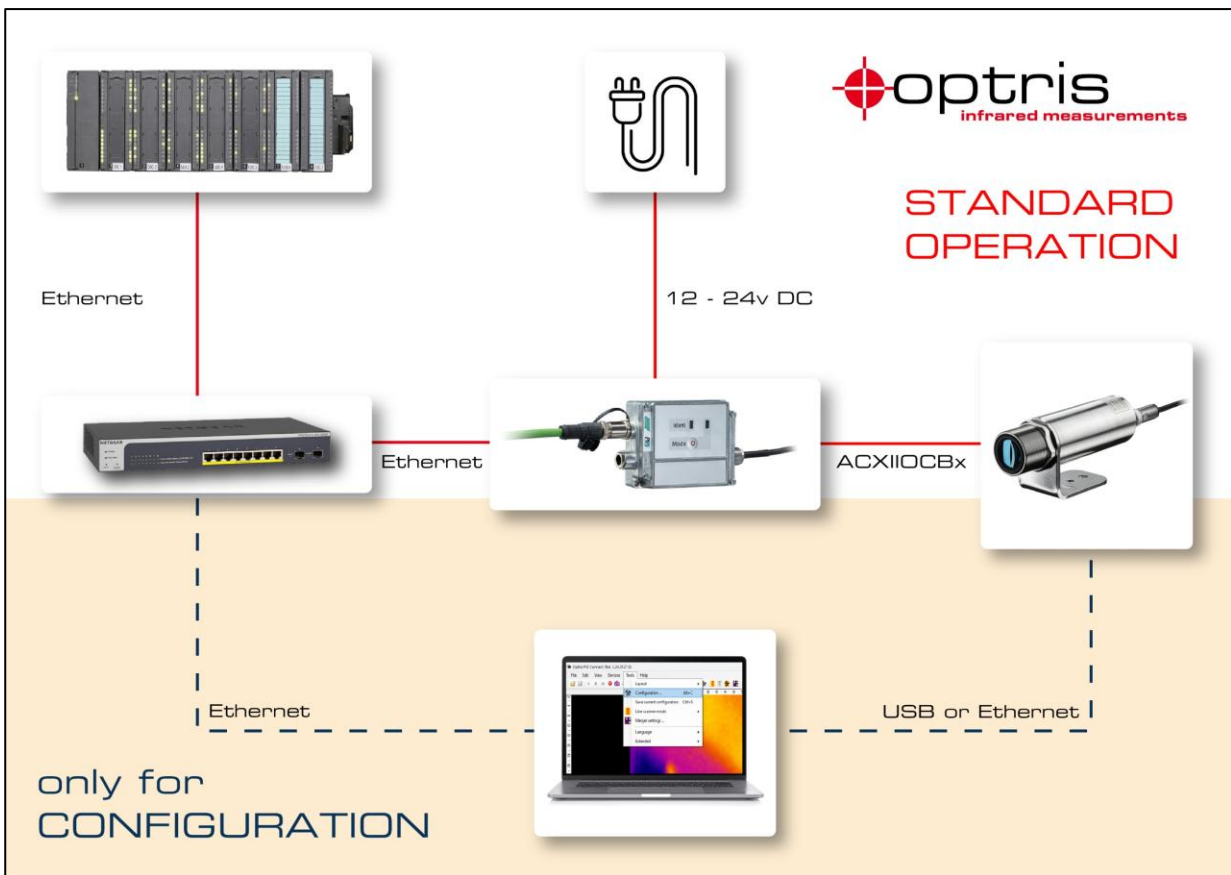

Picture 3: Connection diagram for Profinet Communication Setup



► Note: The PC is only needed for configuration of the imager and the interface and not for operation.

3.2 Preparing the imager for Profinet Communication

Connect the imager with the supplied USB cable to your computer and start the software *PIX Connect*. After the imager has connected to the software and you see the infrared image, manage your **ROI** (Regions of Interests – Measuring areas).

Depending on the imager you can manage up to 9 measure areas (s. table) and 9 additional calculated objects. The calculated objects must consist of the measure areas.

Imager:	Xi 80	Xi 410	Xi 1M 132 x 100 px	Xi 1M 396 x 1 px
max. amount Digital PIF				
measure areas	9	3	9	3
calculated objects	9	9	9	3
response time [ms]	20	640	50	2

In the main window in the menu bar go to **Tools** → **Configuration**.

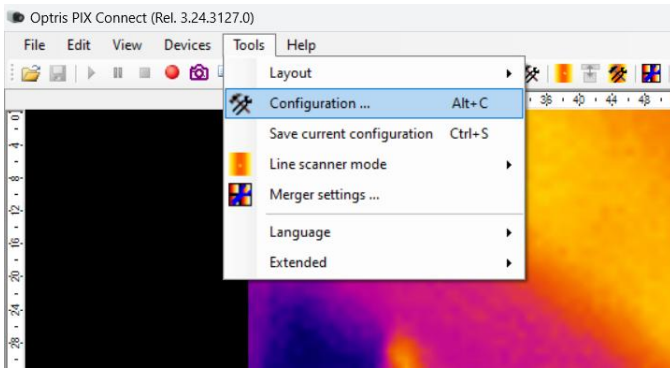

Picture 4: Main menu - PIX Connect

Under the tab **Measure areas** click on **Add (Measure area)** for adding a measuring area or **Add (alculated Area)** for adding a calculated area. Click on OK.

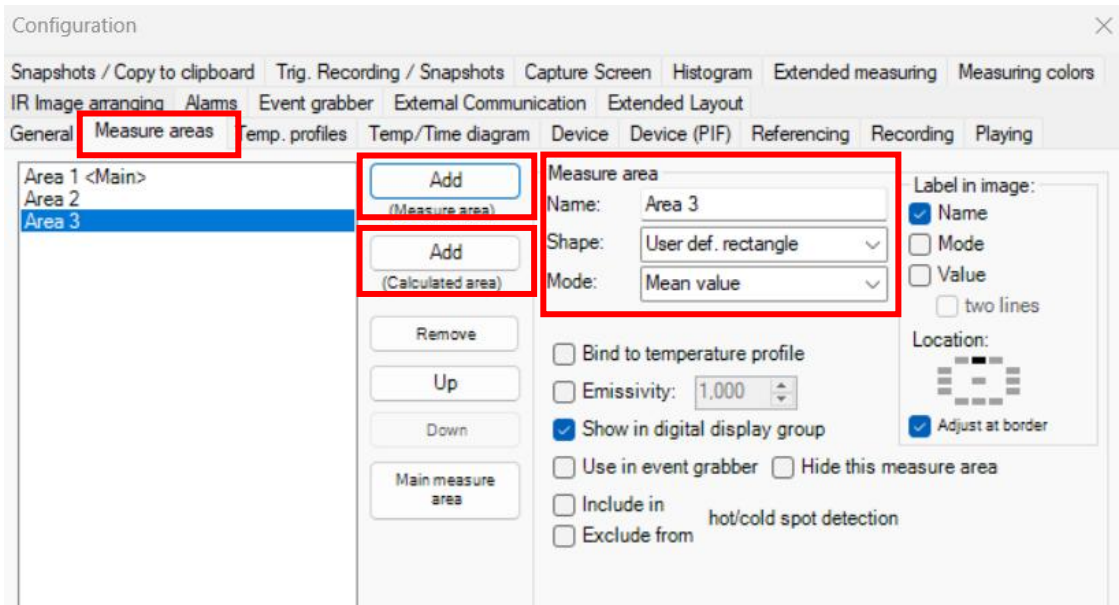

Picture 5: Measure Areas

Now you can move the measure areas or change the shape or mode.

Go to the tab **Device PIF** under configuration and choose the **Digital PIF** in the dropdown menu under **PIF type**.

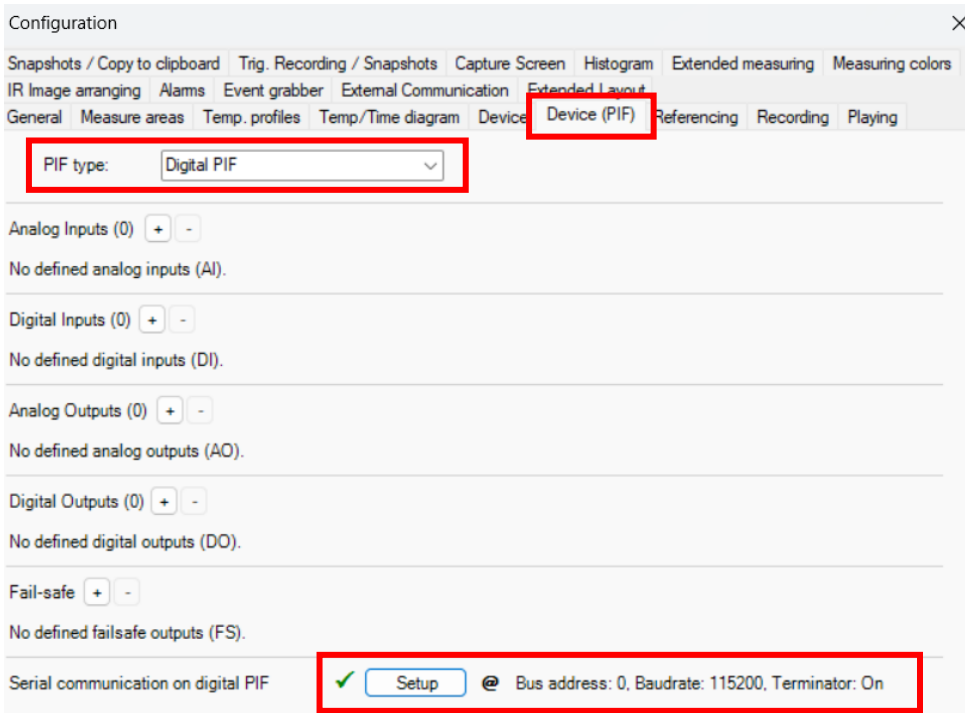

Picture 6: Setting for Process interface

Click on **Setup** in the bottom corner, here is additional information for the Bus address and baud rate.

Here you can set the amount of ROIs which are managed with the Profinet interface. Check the boxes, which you wish the temperature data will be provided to the Profinet interface.

Here in this case (**Picture 7: Example for Measure areas managed for Profinet Communication**) the temperature data of measure areas 1, 3 and 5 and of the calculated object 1 will be provided from the camera to the Profinet interface and to the PLC. The green “@”-sign indicates that everything has been configured correctly and you can proceed to the next step.

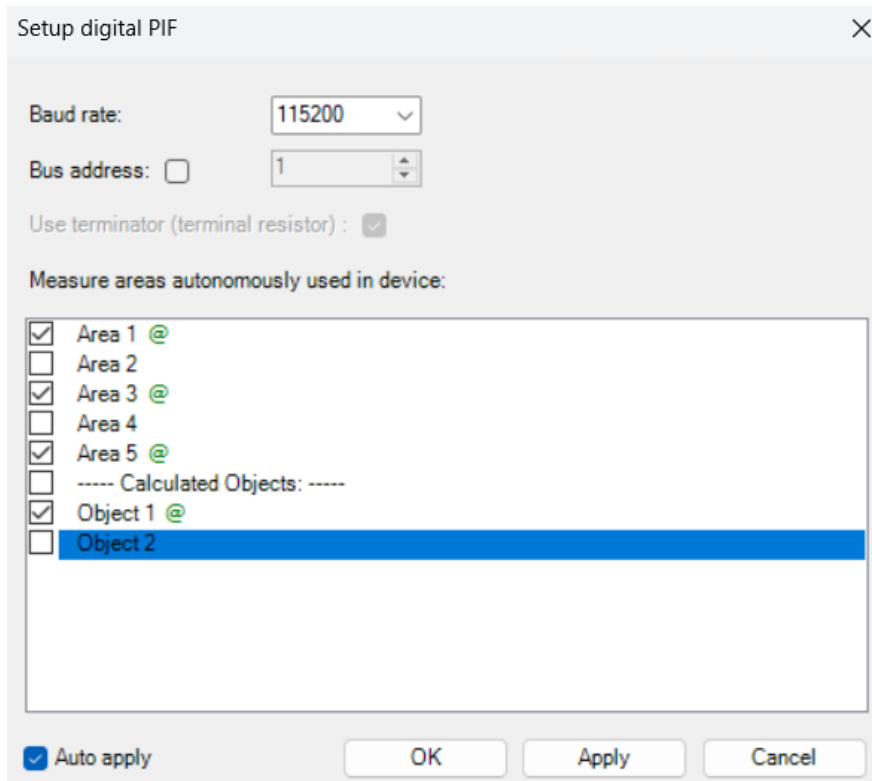

Picture 7: Example for Measure areas managed for Profinet Communication

Make sure, that the **Baud rate** is set to **115200** and the box under **Bus Address** is unchecked. Click on OK.

In the upper status bar of the software PIX Connect you see two cameras with an arrow each. For the imagers Xi 410 and Xi 1M you have to set your configurations to device. Please click on the icon 

and wait a few seconds until the configuration is stored on the camera, both arrows will turn to the color blue. Skip this step for the Xi 80 (the setting will be stored automatically).

Now start the Profinet configuration.

Note: Your PC, the PLC and the Profinetbox have to be in the same network.

4 Manage the Communication

The easiest way to incorporate a Xi-Profinet interface into a PLC programming software Project is by installing the GSD file.

4.1 Installing GSD file

Here you can see an example of installing the GSD file with **SIEMENS TIA Portal V18**.

In the **project tree** go to **Options** → **Manage general station files (GSD)**. Choose your GSD file and click on **install**.

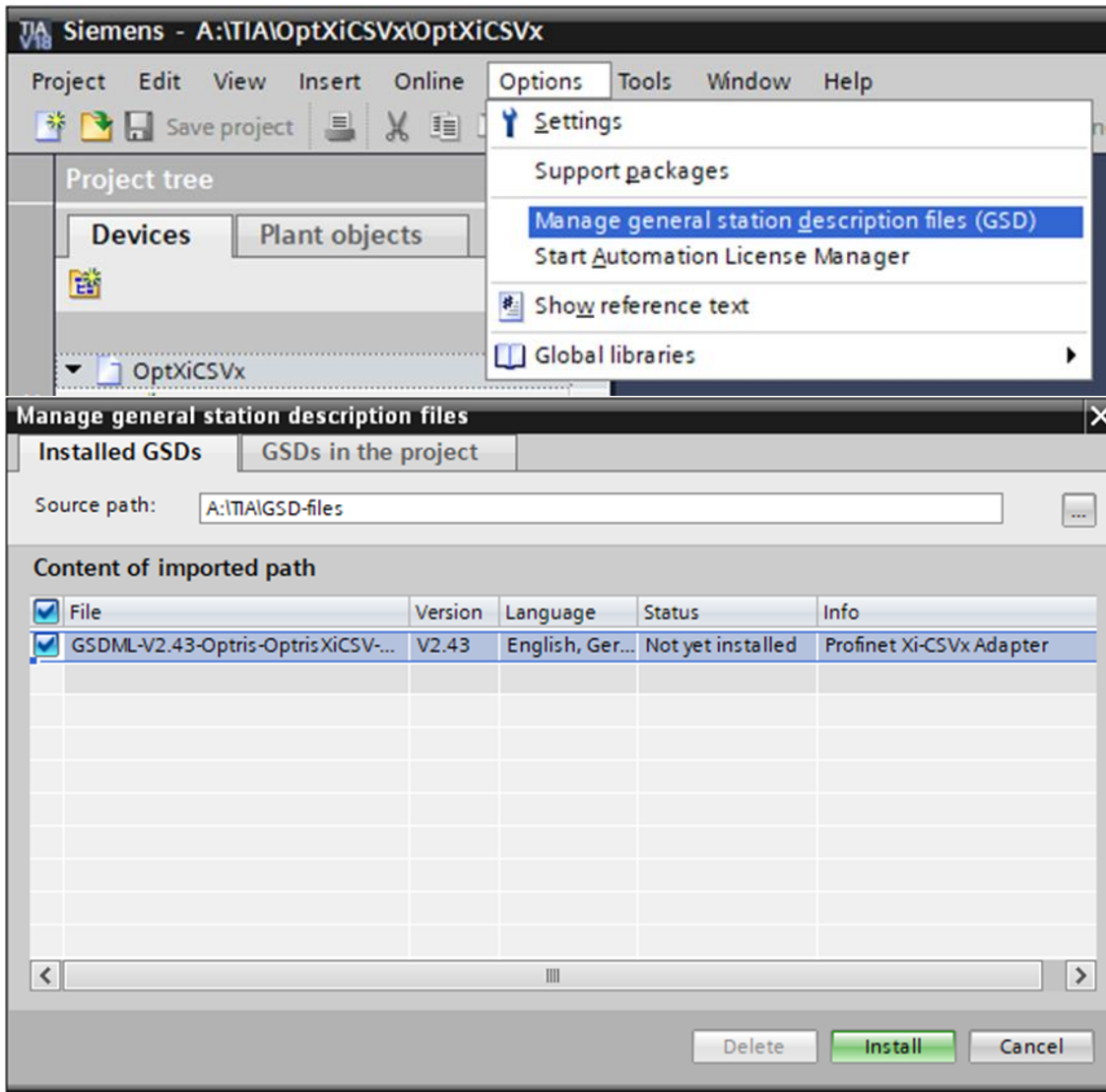

4.2 Installing PLC

In the **project tree** under **Devices** double click on **Add new device**.

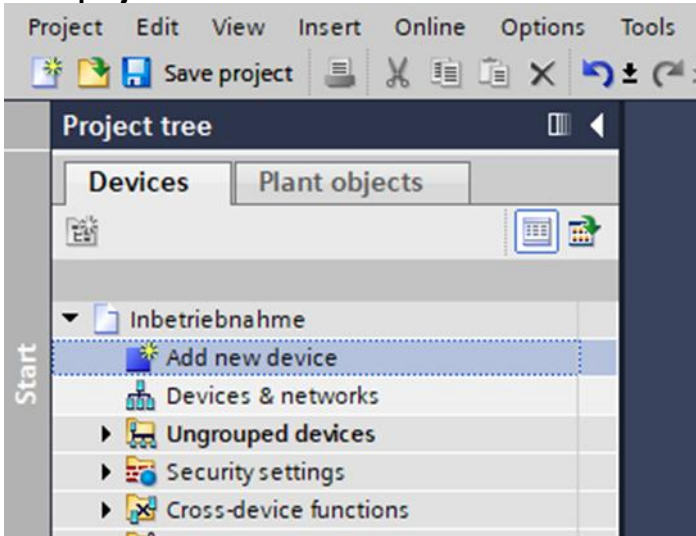

Choose your connected PLC and click **OK**.

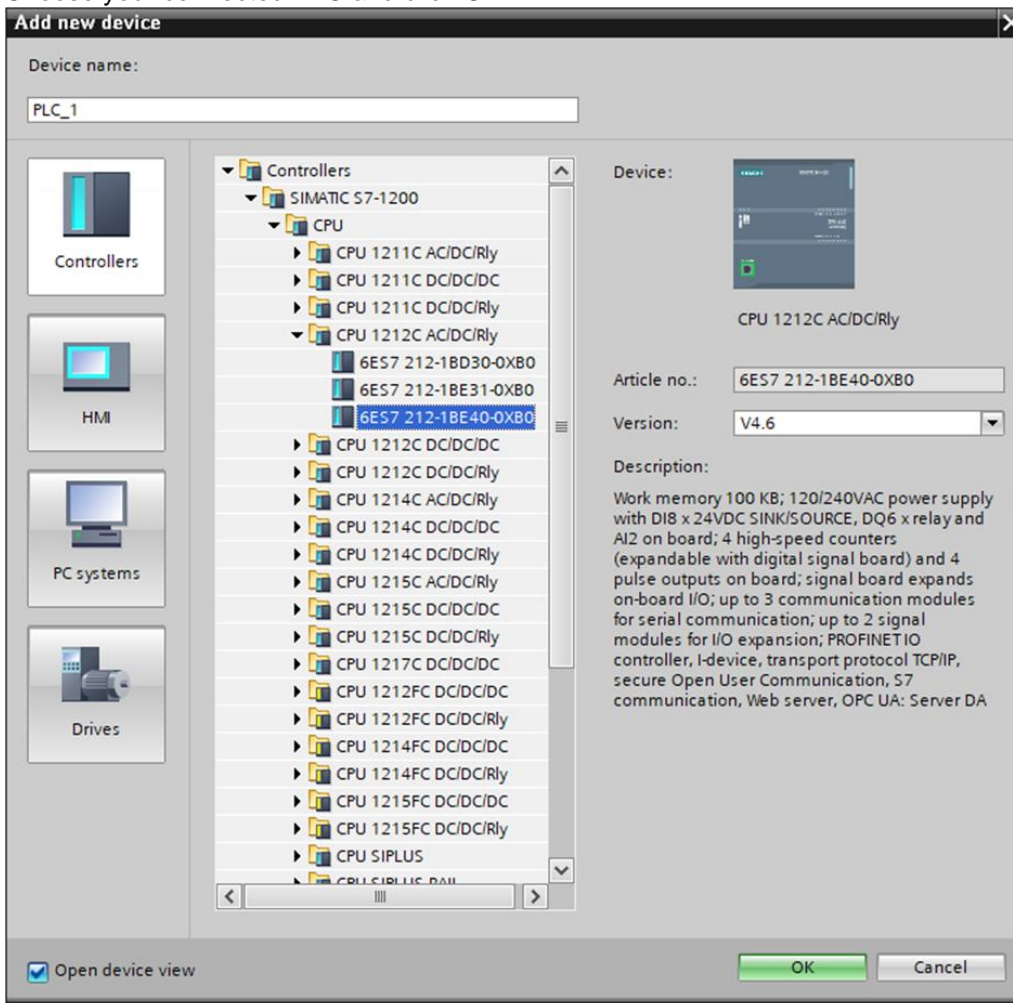

Go through the Settings dialog box of the PLC (depending on customer).

4.3 Configure the Profinet interface

Now you can set up the Profinet interface in the PLC settings.

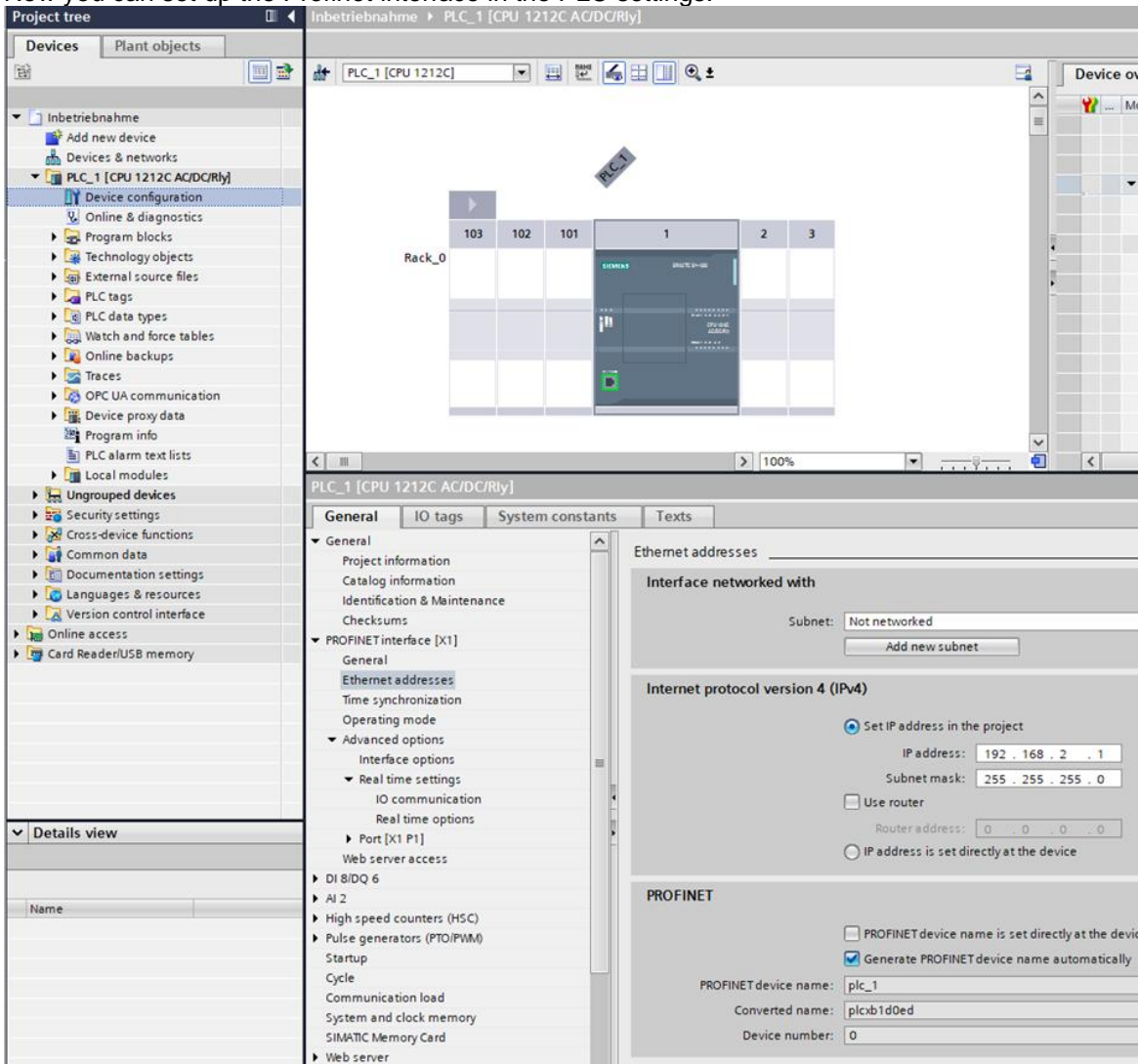

Set the IP address under Internet protocol version 4 (IPv4)

4.4 Add optris Xi-Profinet interface

Click on your project in the **project tree** under Devices. In the menu go to **Online** → **Hardware detection** → **PROFINET devices from network**

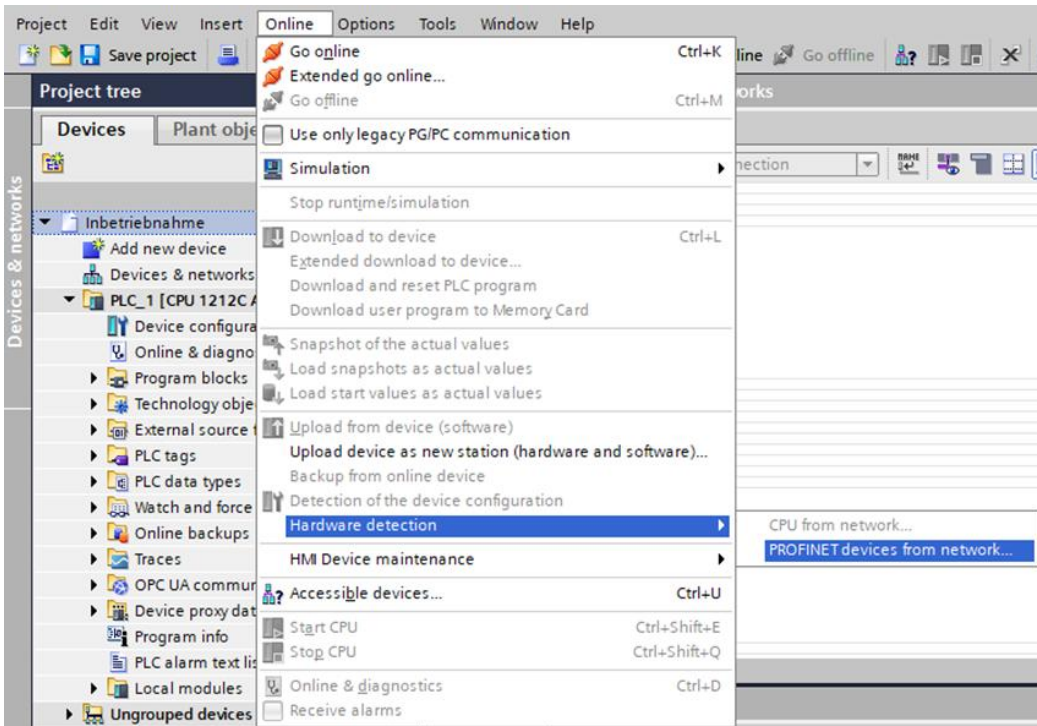

Choose your Ethernet interface and click on Start search.
After the Optris Xi-Profinet interface was found click on Add devices.

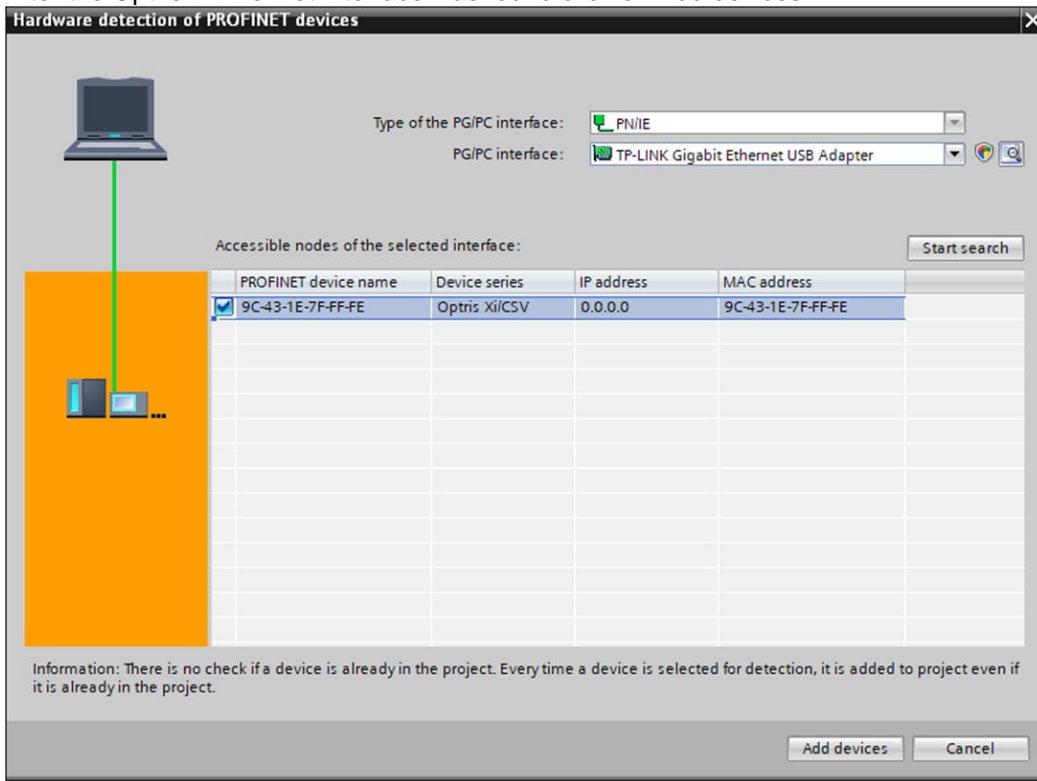

Now your PLC and the Optris Xi-Profinet interface are added to your project.

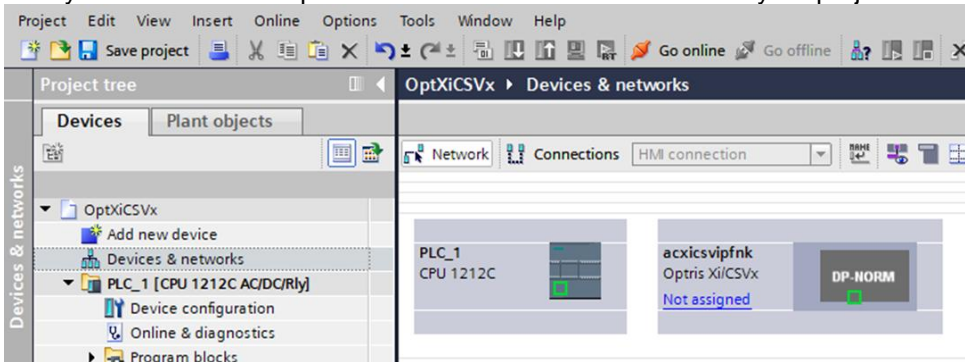

Draw a line with your mouse between the network keys (green boxes).

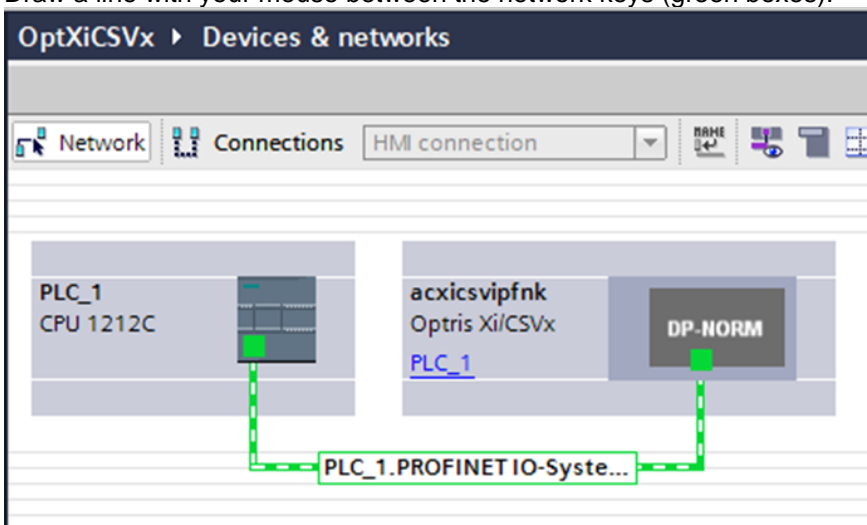

4.5 Rename Optris device

Go to your project in the project tree under **Ungrouped Devices**. Click with the right mouse button on the **Project** and rename it (here: **Optris**). Go to **Optris** device and click on **Assign device name**.



ACXICSVIPFNK-Xi-MA-E2025-02-A

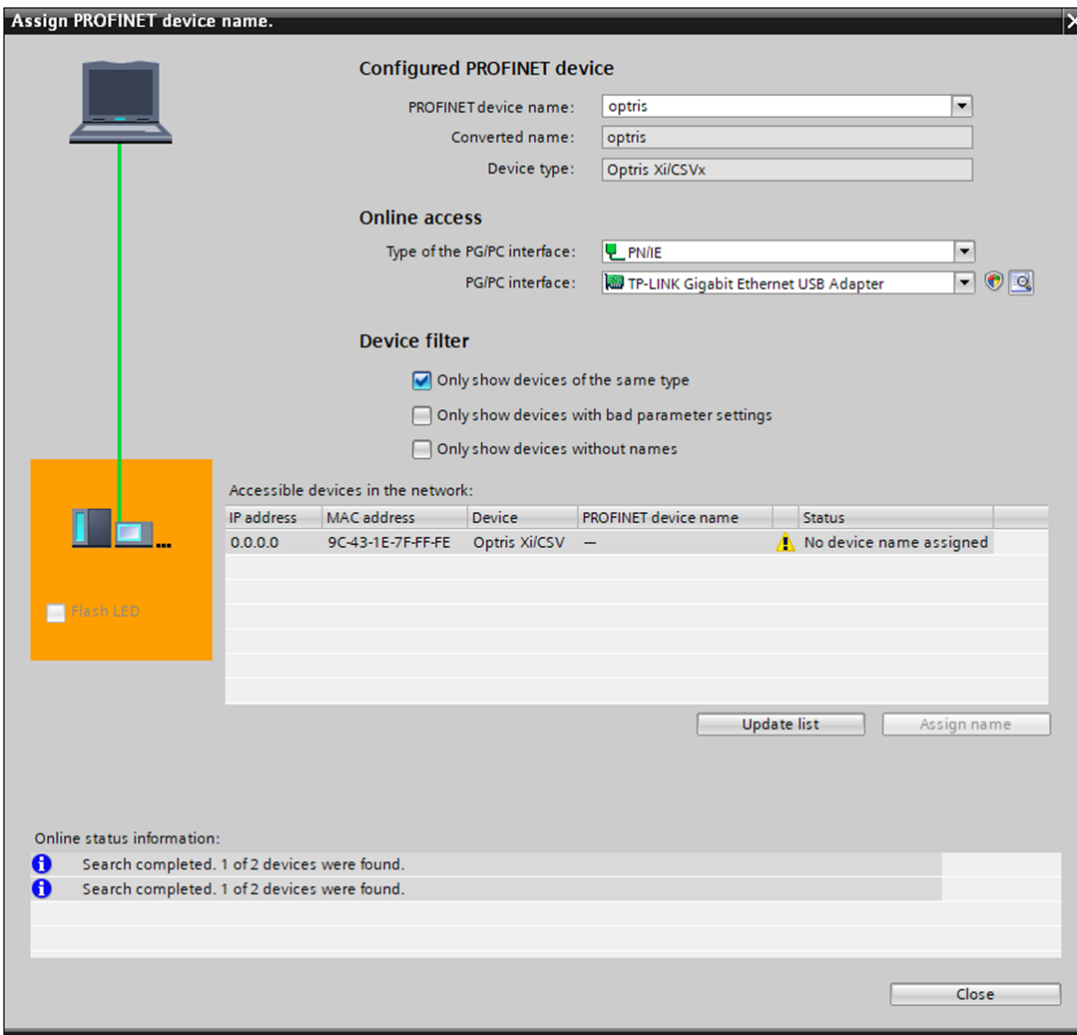

Choose the device and click **Update list**.
 Choose the found device and click **Assign name** and **Close**.

5 Compiling the project

Go to your project in the project tree under **Devices**. Click with the right mouse button on **PLC** → **compile** and on → **Hardware and software (only changes)**.

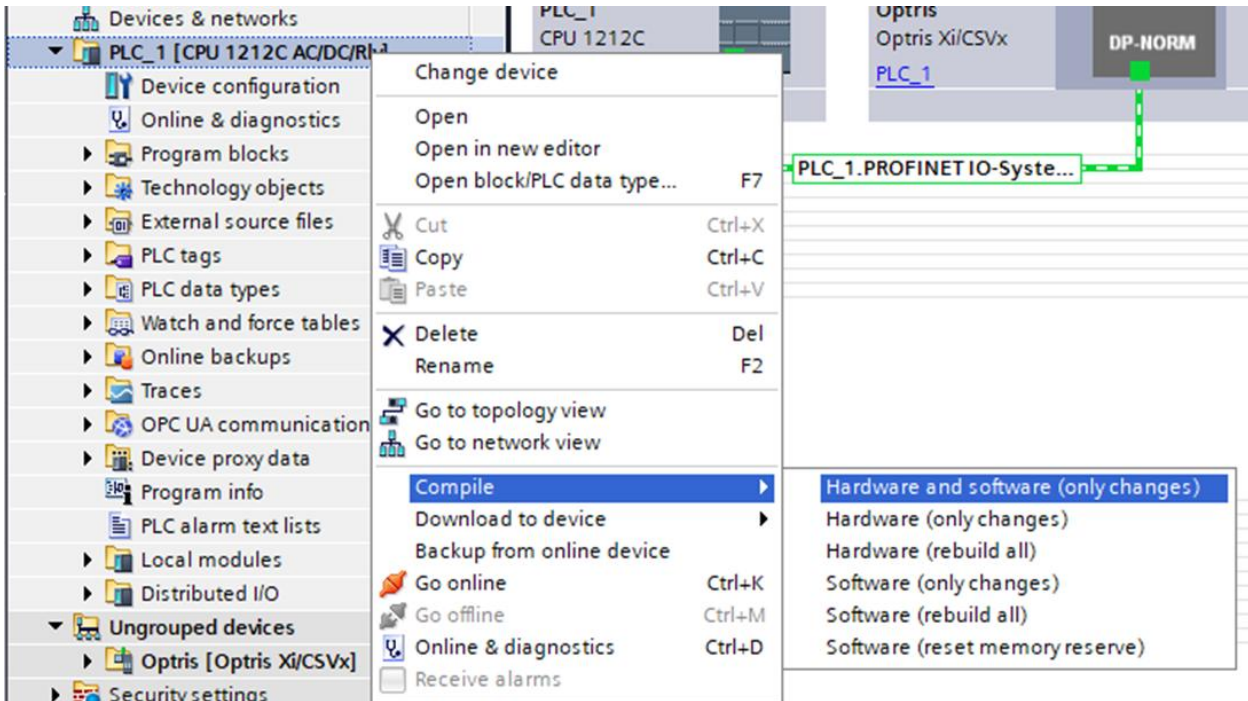

Go to your project in the project tree under **Devices**. Click with the right mouse button on **PLC** → **Download to device** and on → **Hardware and software (only changes)**.

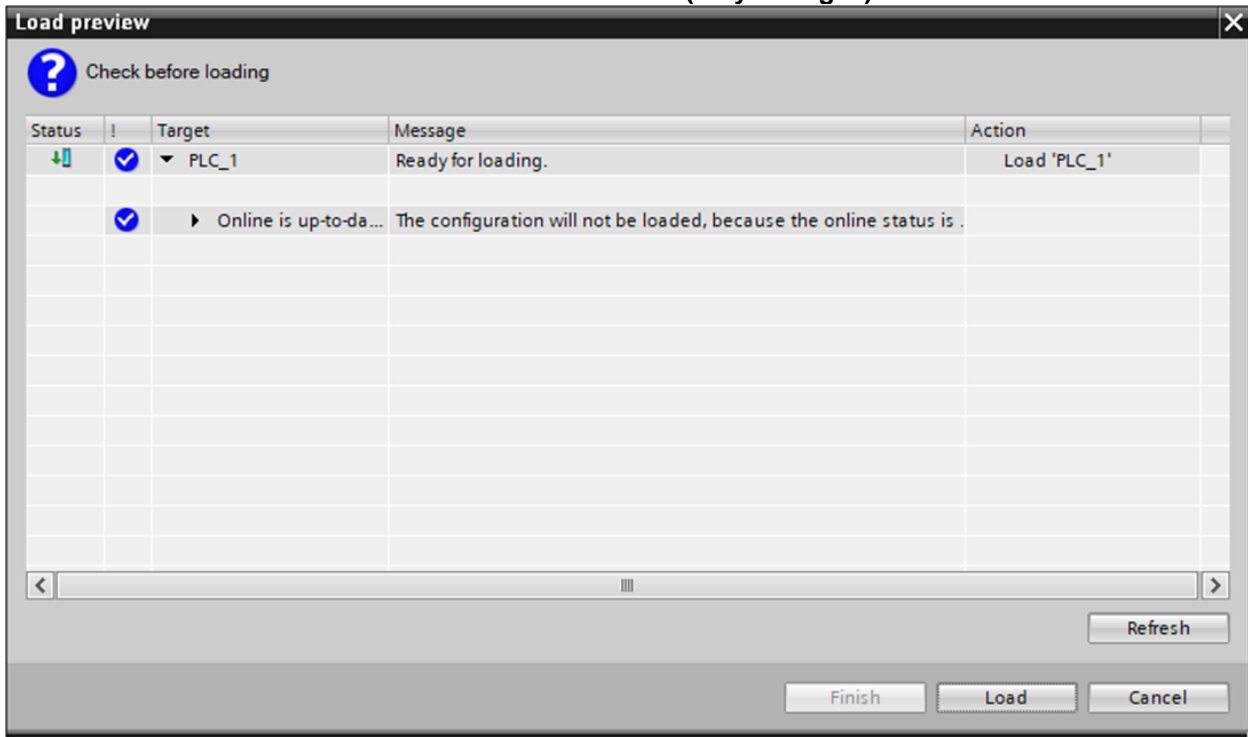

Click on **Load** and after the project was loaded to the PLC click on **Finish**.

6 Strating the project

Go to your project in the project tree under **Devices**. Click with the right mouse button on **PLC** and click on **Go online**.

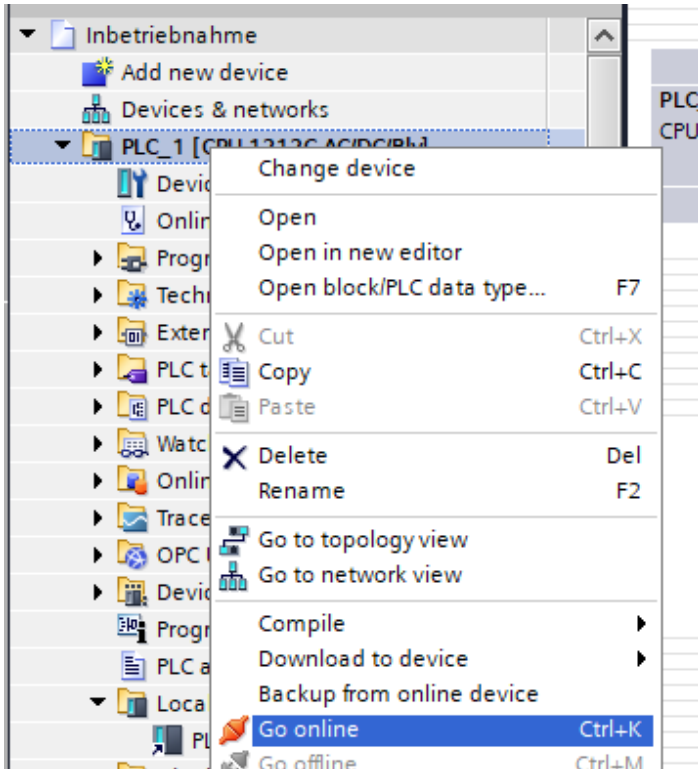

6.1 Show the device data

Click with the right mouse button on **Optris** and **Open**.

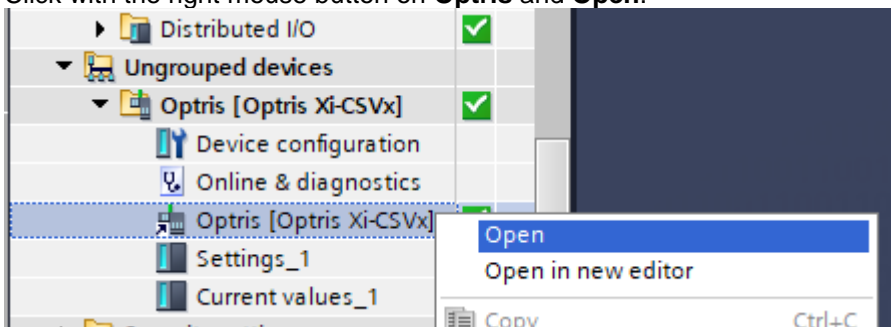

Here you will find all addresses of the single values.

Device overview							
...	Module	Rack	Slot	I address	...	Type	Article no.
✓	▼ Optris	0	0			Optris Xi-CSVx	ACXICSVIPFNK
✓	▶ Interface	0	0 X1			Optris	
✓	Settings_1	0	1			Settings	
✓	▼ Current values_1	0	2			Current values	
✓	Device status	0	2 1	68...71		Device status	
✓	Process temperature	0	2 2	72...75		Process temperature	
✓	Head temperature	0	2 3	76...79		Head temperature	
✓	Ratio temperature	0	2 4	80...83		Ratio temperature	
✓	T1 temperature	0	2 5	84...87		T1 temperature	
✓	T2 temperature	0	2 6	88...91		T2 temperature	
✓	Attenuation	0	2 7	92...95		Attenuation	
✓	Current emissivity	0	2 8	96...99		Current emissivity	
✓	Current transmission	0	2 9	100...103		Current transmission	
✓	Current slope	0	2 10	104...107		Current slope	
✓	IO1 voltage	0	2 11	108...111		IO1 voltage	
✓	Flag state	0	2 12	112		Flag state	
✓	Area count	0	2 13	113		Area count	
✓	Temperature area 1	0	2 14	114...117		Temperature area 1	
✓	Temperature area 2	0	2 15	118...121		Temperature area 2	
✓	Temperature area 3	0	2 16	122...125		Temperature area 3	
✓	Temperature area 4	0	2 17	126...129		Temperature area 4	
✓	Temperature area 5	0	2 18	130...133		Temperature area 5	
✓	Temperature area 6	0	2 19	134...137		Temperature area 6	
✓	Temperature area 7	0	2 20	138...141		Temperature area 7	
✓	Temperature area 8	0	2 21	142...145		Temperature area 8	
✓	Temperature area 9	0	2 22	146...149		Temperature area 9	
✓	Temperature calculated object 1	0	2 23	150...153		Temperature calculated object 1	
✓	Temperature calculated object 2	0	2 24	154...157		Temperature calculated object 2	
✓	Temperature calculated object 3	0	2 25	158...161		Temperature calculated object 3	
✓	Temperature calculated object 4	0	2 26	162...165		Temperature calculated object 4	
✓	Temperature calculated object 5	0	2 27	166...169		Temperature calculated object 5	
✓	Temperature calculated object 6	0	2 28	170...173		Temperature calculated object 6	
✓	Temperature calculated object 7	0	2 29	174...177		Temperature calculated object 7	
✓	Temperature calculated object 8	0	2 30	178...181		Temperature calculated object 8	
✓	Temperature calculated object 9	0	2 31	182...185		Temperature calculated object 9	

The addresses will be needed for creating new variables in the project: Double click on PLC and click on **Show all tags**.

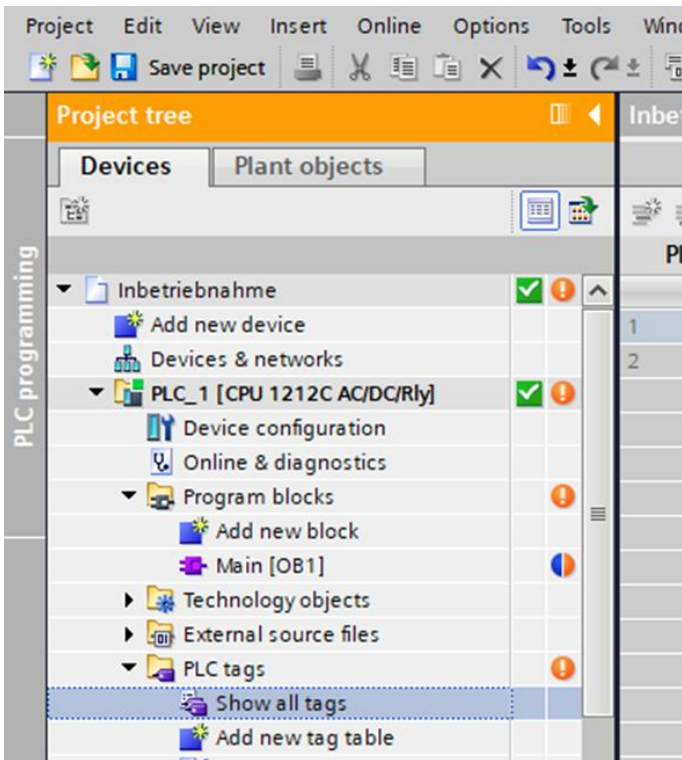

Here you can create new values.

PLC tags									
	Name	Tag table	Data type	Address	Retain	Acces...	Writa...	Visibl...	Corr
1	Process temp.	Default tag table	Real	%ID72	<input type="checkbox"/>	<input checked="" type="checkbox"/>	<input checked="" type="checkbox"/>	<input checked="" type="checkbox"/>	
2	Head temp.	Default tag table	Real	%ID76	<input type="checkbox"/>	<input checked="" type="checkbox"/>	<input checked="" type="checkbox"/>	<input checked="" type="checkbox"/>	
3	Area 1 temp.	Default tag table	Real	%ID114	<input type="checkbox"/>	<input checked="" type="checkbox"/>	<input checked="" type="checkbox"/>	<input checked="" type="checkbox"/>	
4	<Add new>				<input type="checkbox"/>	<input checked="" type="checkbox"/>	<input checked="" type="checkbox"/>	<input checked="" type="checkbox"/>	



Click on the symbol "glasses with the green arrow"

Now you see the values in the tab **Monitor value**.

PLC tags									
	Name	Tag table	Data type	Address	Retain	Acces...	Writa...	Visibl...	Monitor value
1	Process temp.	Default tag table	Real	%ID72	<input type="checkbox"/>	<input checked="" type="checkbox"/>	<input checked="" type="checkbox"/>	<input checked="" type="checkbox"/>	31.5
2	Head temp.	Default tag table	Real	%ID76	<input type="checkbox"/>	<input checked="" type="checkbox"/>	<input checked="" type="checkbox"/>	<input checked="" type="checkbox"/>	29.3
3	Area 1 temp.	Default tag table	Real	%ID114	<input type="checkbox"/>	<input checked="" type="checkbox"/>	<input checked="" type="checkbox"/>	<input checked="" type="checkbox"/>	28.7
4	<Add new>				<input type="checkbox"/>	<input checked="" type="checkbox"/>	<input checked="" type="checkbox"/>	<input checked="" type="checkbox"/>	

7 Read and write device Information

Read and write of Information via "RDREC" und "WRREC" direct to/from the device:

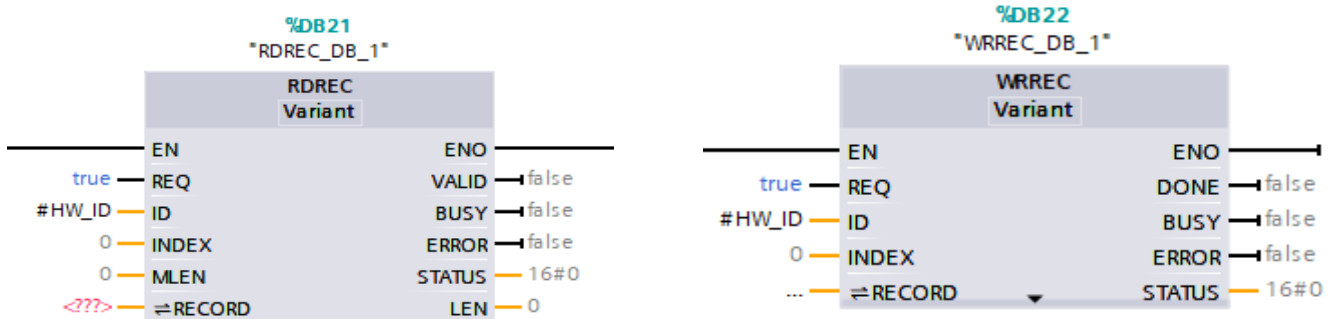

Parameter :

HW_ID Optris~Current_values_1~Device_status

INDEX	MLEN	RECORD (Typ)	Value	Notice
16#03e9	4	DWORD	Serial number	
16#03ea	2	WORD	FW Revision	
16#03eb	1	BOOL	Temp. unit	false - °F true - °C
16#03ec	4	REAL	Measuring range 1 min	
16#03ed	4	REAL	Measuring range 1 max	
16#03ee	4	REAL	Measuring range 2 min	
16#03ef	4	REAL	Measuring range 3 min	
16#03f0	4	BYTE	Device Temp. Range min	
16#03f1	4	REAL	Device Temp. Range max	
16#03f2	24	ARRAY[0..23] OF CHAR	Device description	
16#03f3	8	ARRAY[0..4] OF BYTE	Device Flags	
16#044c	1	BYTE	Xi area 1 mode	
16#044d	1	BYTE	Xi area 2 mode	
16#044e	1	BYTE	Xi area 3 mode	
16#044f	1	BYTE	Xi area 4 mode	
16#0450	1	BYTE	Xi area 5 mode	
16#0451	1	BYTE	Xi area 6 mode	
16#0452	1	BYTE	Xi area 7 mode	
16#0453	1	BYTE	Xi area 8 mode	
16#0454	1	BYTE	Xi area 9 mode	
16#0456	4	REAL	Xi area 1 emissivity	
16#0457	4	REAL	Xi area 2 emissivity	
16#0458	4	REAL	Xi area 3 emissivity	
16#0459	4	REAL	Xi area 4 emissivity	
16#045a	4	REAL	Xi area 5 emissivity	
16#045b	4	REAL	Xi area 6 emissivity	
16#045c	4	REAL	Xi area 7 emissivity	

16#045d	4	REAL	Xi area 8 emissivity	
16#045e	4	REAL	Xi area 9 emissivity	
16#0460	4	REAL	Xi area 1 d. range min *	
16#0461	4	REAL	Xi area 2 d. range min *	
16#0462	4	REAL	Xi area 3 d. range min *	
16#0463	4	REAL	Xi area 4 d. range min *	
16#0464	4	REAL	Xi area 5 d. range min *	
16#0465	4	REAL	Xi area 6 d. range min *	
16#0466	4	REAL	Xi area 7 d. range min *	
16#0467	4	REAL	Xi area 8 d. range min *	
16#0468	4	REAL	Xi area 9 d. range min *	
16#046b	4	REAL	Xi area 1 d. range max *	
16#046c	4	REAL	Xi area 2 d. range max *	
16#046d	4	REAL	Xi area 3 d. range max *	
16#046e	4	REAL	Xi area 4 d. range max *	
16#046f	4	REAL	Xi area 5 d. range max *	
16#0470	4	REAL	Xi area 6 d. range max *	
16#0471	4	REAL	Xi area 7 d. range max *	
16#0472	4	REAL	Xi area 8 d. range max *	
16#0473	4	REAL	Xi area 9 d. range max *	

* min. or max. distribution range

8 Read and write device Settings

Parameter :

HW_ID Optris~Settings_1

INDEX	MLEN	RECORD (Typ)	Value	Notice
16#0001	1	BOOL	Temp. unit	false - °F true - °C
16#0002	1	BOOL	Laser on	false true
16#0003	4	REAL	Emissivity	
16#0004	4	REAL	Transmission	
16#0005	4	REAL	Slope	
16#0006	4	REAL	Emissivity T1	
16#0007	1	BYTE	Average Mode	0 - normal 1 - Smart
16#0008	4	REAL	Average time	
16#000c	4	REAL	Threshold for Smart Mode	
16#000d	4	REAL	max. Attenuation	
16#000e	1	BYTE	max. Attenuation Mode	
16#0010	4	REAL	max. Attenuation Fix Value	
16#0011	4	REAL	Fix. Ambient Temp.	
16#0014	4	REAL	focusmotor position	%
16#0015	1	BYTE	Filter motor position	0,1,2 only CSVx
16#0016	1	BYTE	Flag state	0- open 1- close

9 Tunnel commands – direct device communication

This feature allows you via tunnel to have access to all device settings.

Parameter :

HW_ID Optris~Current_values_1~Device_status
INDEX 10001
RECORD Variable vom Typ "Array [0..x] of Byte"

Example : Read Xi Firmware Revision	
Record = Array[0..4] of Byte	
Record[0] := 16#00	
Record[1] := 16#00	Always „0“
Record[2] := 16#00	
Record[3] := 16#64	← Xi command Timeout in ms
Record[4] := „?“	← Xi command “?FWVer” read f/w and h/w Revision
Record[5] := „F“	
Record[6] := „W“	
Record[7] := „V“	
Record[8] := „e“	
Record[9] := „r“	
WRREC execute	
RDREC execute	
Record[0] := 16#00	
Record[1] := 16#02	← answer number of bytes
Record[2] := „!“	← Xi answer „!FWVer=1234, 5678“
Record[5] := „F“	
Record[6] := „W“	
Record[7] := „V“	
Record[8] := „e“	
Record[9] := „r“	
Record[5] := „=“	
Record[6] := „1“	
Record[7] := „2“	
Record[8] := „3“	
Record[9] := „4“	
Record[5] := „,“	
Record[6] := „ “	
Record[7] := „5“	
Record[8] := „6“	
Record[9] := „7“	
Record[9] := „8“	



10 Contact information

Optris GmbH & Co. KG
Ferdinand-Buisson-Str. 14
13127 Berlin
Germany

Tel.: +49 30 500197-0
Fax.: +49 30 500197-10

email: info@optris.com
web: www.optris.com